

As approved by the Rover  
Co. Ltd. for use with the

# AUTOMETRIC

## Nylon Roller Vane Pump



- ★ QUICK FITTING TO LAND ROVER OR TRACTOR P.T.O. SHAFT
- ★ QUICK PRESSURE CONTROL
- ★ EASY MAINTENANCE

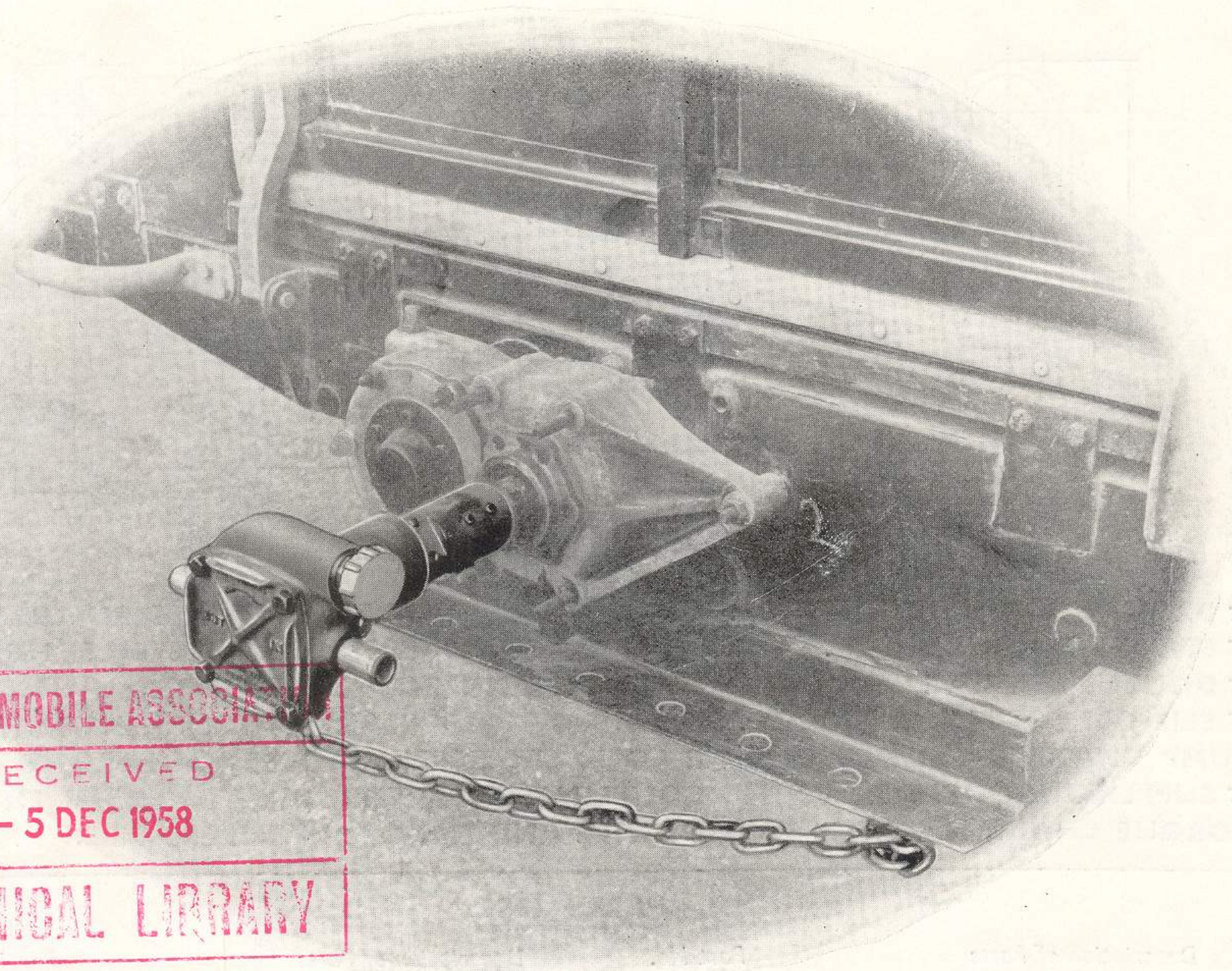

THE AUTOMOBILE ASSOCIATION  
RECEIVED  
- 5 DEC 1958  
TECHNICAL LIBRARY

- ★ PRESSURES UP TO 80 P.S.I. AT 540 R.P.M.
- ★ SELF PRIMING
- ★ OUTPUT 360 GALLONS PER HOUR
- ★ ROBUST & PORTABLE

Manufactured by **AUTOMETRIC PUMPS LTD.**  
**WATERSIDE · MAIDSTONE · KENT · ENGLAND**

Telephone : Maidstone 4728.

Cables & Grams : AUTOMETRIC Maidstone.

Codes : Bentley's Complete and Second Phrase.

# SPECIFICATION & DETAILS OF THE RS50/HV

## AUTOMETRIC Nylon Roller Vane Pump with Handwheel Pressure Control

### EMERGENCY FIREFIGHTING

### WASHDOWN-TRACTOR, LORRY, CAR, EQUIPMENT AND BUILDINGS

### SPRAYING - CATTLE, WEEDS, CROPS AND FRUIT

### HIGH OR LOW PRESSURE BY HAND WHEEL CONTROL

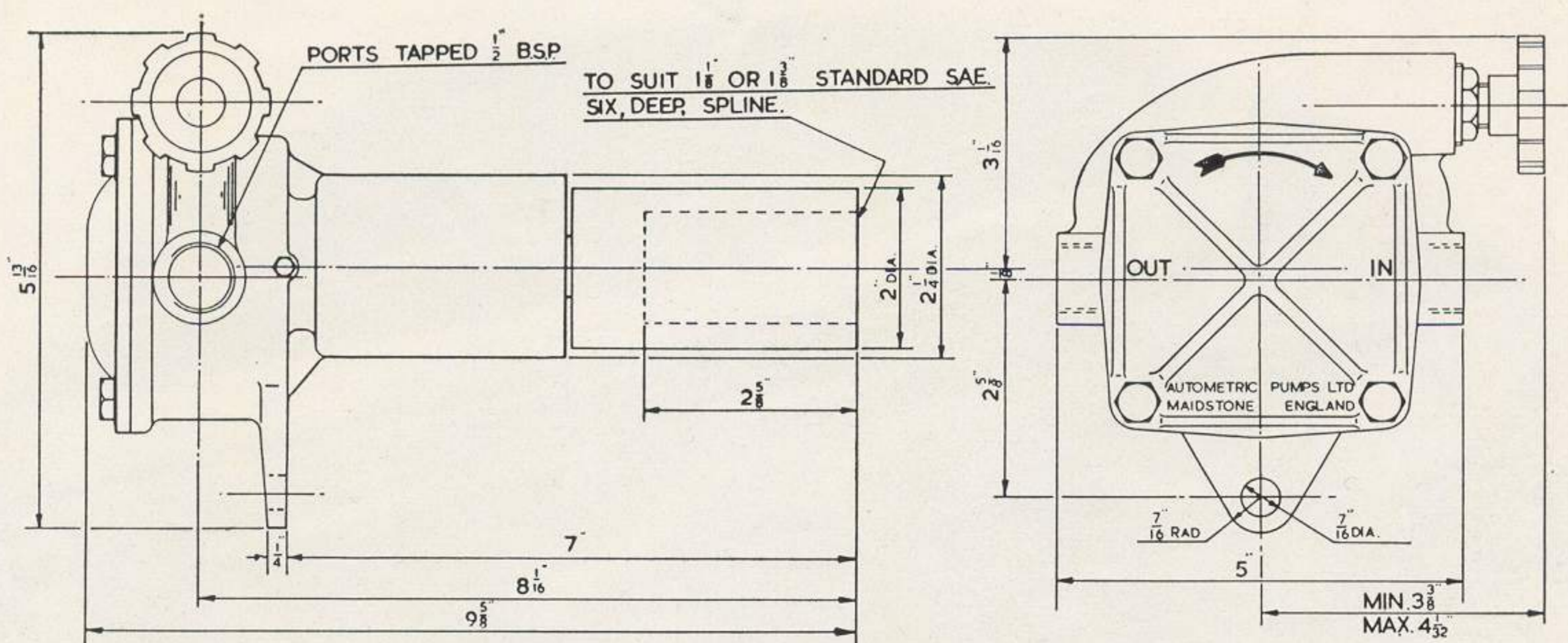

DIMENSIONS OF THE RS50/HV UNIT.

- ★ BRONZE CASING AND ROTOR.
- ★ STAINLESS STEEL SHAFT.
- ★ DOUBLE SEALED LIFE LUBRICATED BALL AND ROLLER BEARINGS.
- ★ SLIP ON COUPLING TO P.T.O. SHAFT.
- ★ SUPPLIED COMPLETE WITH COUPLING, ADAPTOR SLEEVE, FILTER, NOZZLE, TORQUE CHAIN, 10ft. OF  $\frac{3}{4}$ " SUCTION PIPE AND 20ft. OF  $\frac{1}{2}$ " DELIVERY PIPE.
- ★ NYLON COVERED ROLLER VANES.
- ★ PRESSURE RELIEVED SEALS.
- ★ READY INTERNAL INSPECTION OF PUMP CHAMBER—SIMPLY RELEASE FOUR SET SCREWS TO REMOVE FRONT COVER.

### PARTS LIST

Description of Parts	Part No.	Description of Parts	Part No.
ROTOR & KEY	C2013/A 15-3	COUPLING SCREW	B2813
VALVE ASSEMBLY	C2013/A 17-23	ADAPTOR SLEEVE	A2188
"O" RING	C2013/A 2	TORQUE CHAIN	A2058
COUPLING	B2186/A		

WEIGHTS & CASE DIMENSIONS FOR EXPORT. Net Wt. 22lbs. Gross Wt. 38lbs. Case Size 17" x 17" x 13"

### LAND ROVER EXTRAS REQUIRED :-

REAR POWER TAKE-OFF

HAND THROTTLE FOR PETROL ENGINES