

As approved by the Rover  
Co., Ltd., for use with the

# AUTOMETRIC

## Multi - stage Turbine Pump

LAND-  
ROVER

- ★ OUTPUTS UP TO 2500 GALLONS PER HOUR
- ★ PRESSURES UP TO 100 P.S.I. AT 1720 R.P.M.

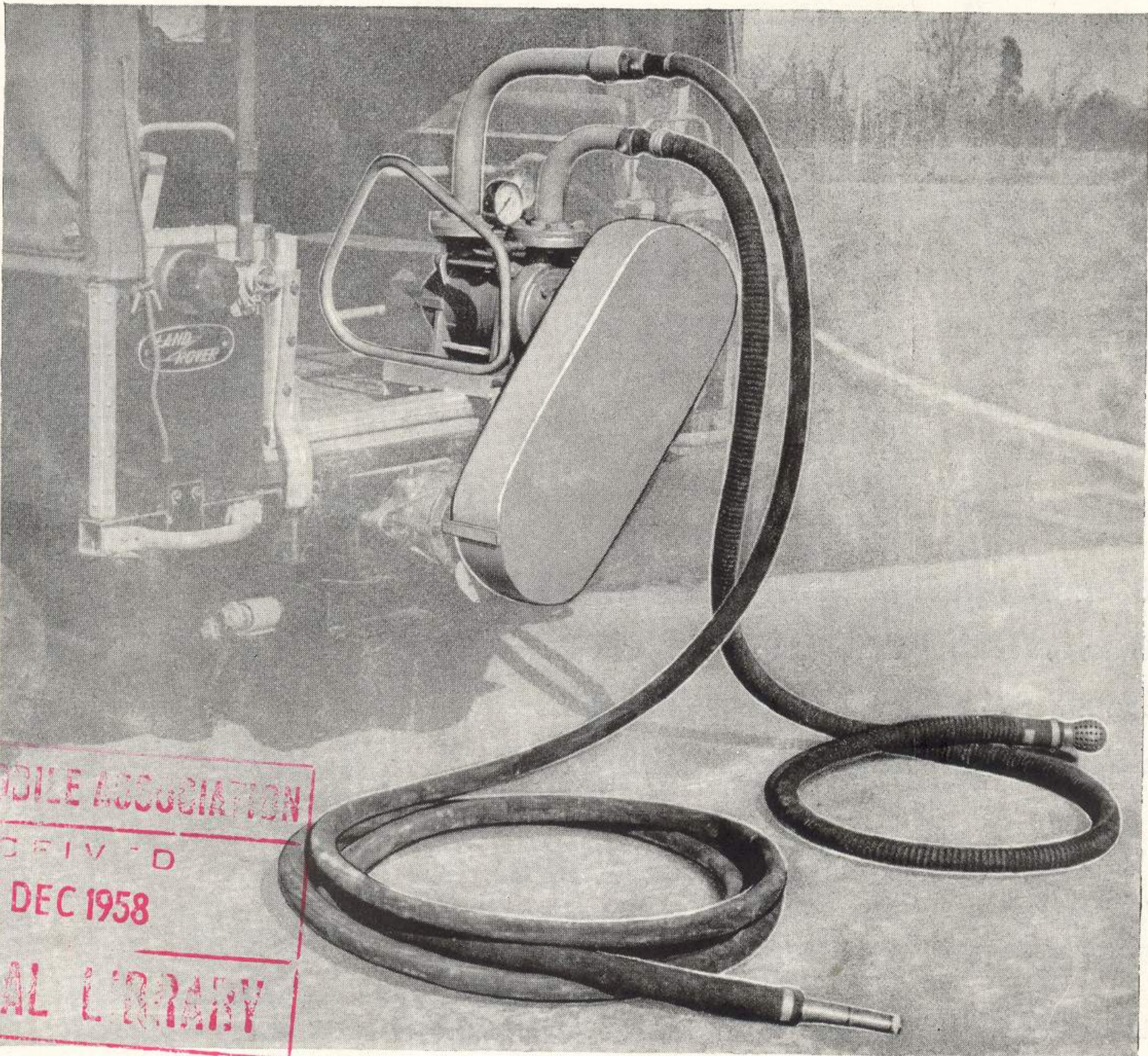

THE AUTOMOBILE ASSOCIATION  
RECEIVED  
- 5 DEC 1958  
TECHNICAL LIBRARY

- ★ SUCTION LIFTS UP TO 27 FEET
- ★ SELF PRIMING

Manufactured by **AUTOMETRIC PUMPS LTD.**  
**WATERSIDE • MAIDSTONE • KENT • ENGLAND**

Telephone : Maidstone 4728.

Cables & Grams : AUTOMETRIC Maidstone.

Codes : Bentley's Complete and Second Phrase,

PDF by roby65to



# SPECIFICATION & DETAILS of the HA7502 AUTOMETRIC Multi-stage Turbine Pump powered by Land Rover

★ LIQUID TRANSFER

★ EMERGENCY FIREFIGHTING

★ PRESSURE BOOSTING

★ SPRAYING

★ WASHDOWN

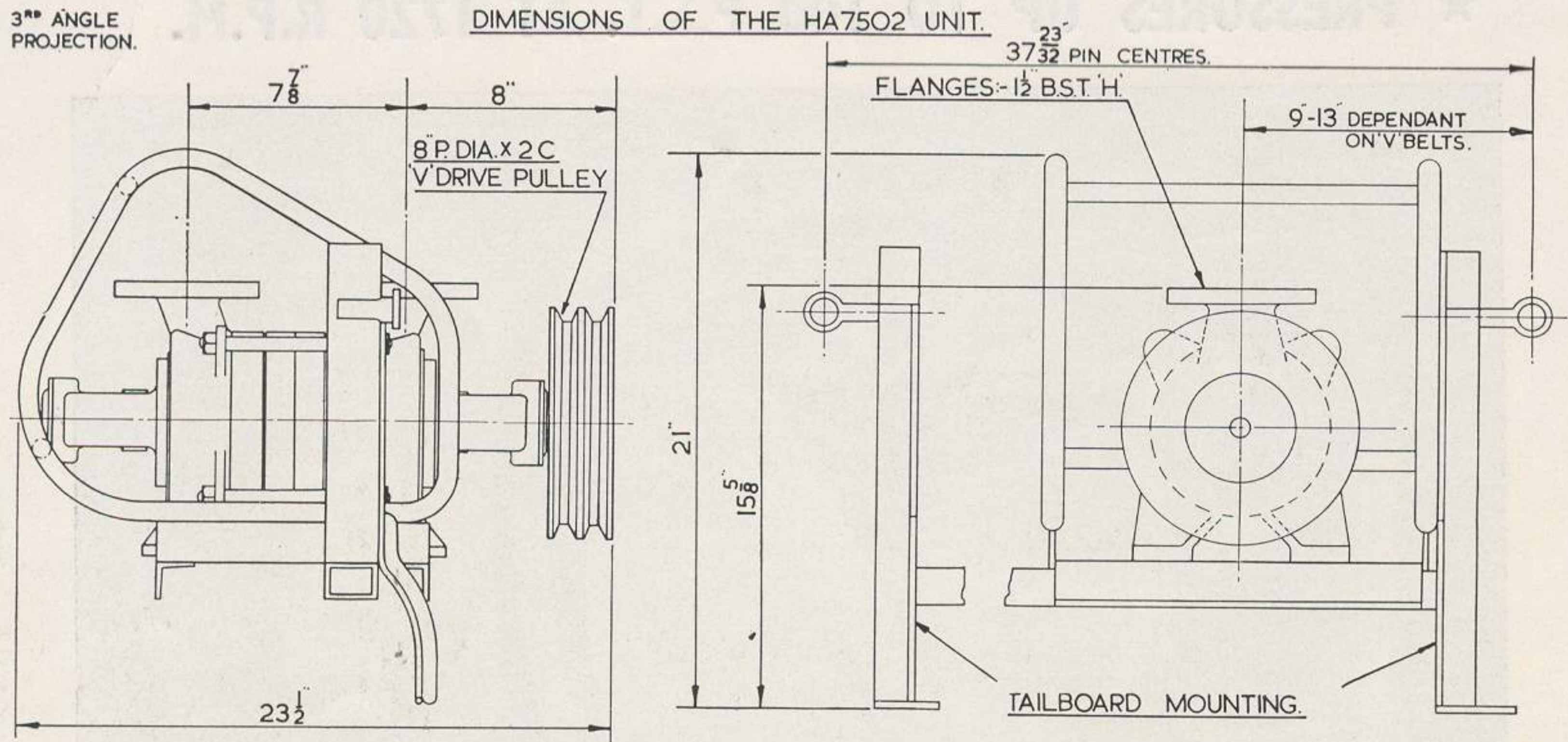

★ RIGID MAIN HOUSING WITH FLANGED PORTS.

★ STAINLESS STEEL IMPELLERS AND SHAFT.

★ OUTBOARD BALL AND ROLLER BEARINGS.

★ NO BEARINGS IN FLUID BEING HANDLED.

### PARTS LIST

Description of Part	Part No.	Qty Per Set	Description of Part	Part No.	Qty Per Set
TAILBOARD MOUNTING	B2815	1	PULLEY BELT	C55	2
PUMP	C2684	1	BELT GUARD	B2812	1
PUMP PULLEY 8" Pitch Dia.		1	SPLINED PULLEY	B2824	1

WEIGHTS & CASE DIMENSIONS FOR EXPORT. Net Wt. 170lbs. Gross Wt. 220lbs. Case Size 44" x 29" x 27"

### LAND ROVER EXTRAS REQUIRED :-

REAR POWER TAKE-OFF

HAND THROTTLE FOR PETROL ENGINES