

BY APPOINTMENT TO HER MAJESTY THE QUEEN  
MILKING MACHINE MANUFACTURERS  
GASCOIGNES (READING) LTD.



As approved by  
the Rover Company Limited  
for use with the

# Gascoignes

## VACUUM POWER SET

**LAND-  
ROVER**

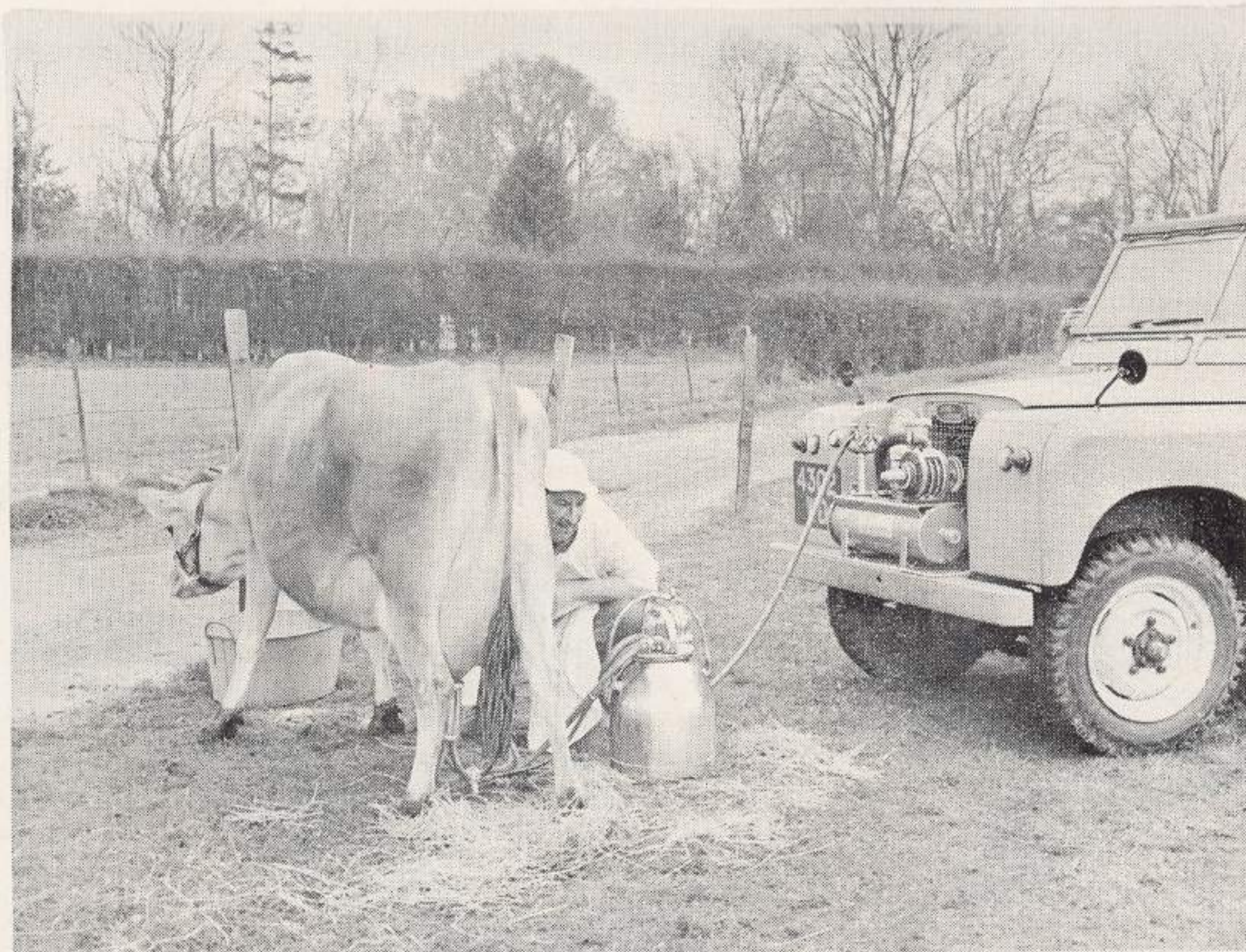

Some uses for this versatile and fully portable equipment include.

Milking in the cattle lines at agricultural shows or as a field milker on the farm.

Supplying vacuum to small milking bails which only ties up the Land Rover for the duration of milking.

Creating the necessary vacuum to empty slurry tanks where only low pressure is required.

Any application where a portable vacuum pump is needed i.e. for vacuum sheep shearing etc. or any stand-by use where vacuum is the primary source of power.

THE AUTOMOBILE ASSOCIATION

RECEIVED

27 APR 1965

TECHNICAL LIBRARY

The Vacuum Pump unit is mounted on the front bumper of the Land Rover secured by four bolts so that it can be readily detached if required.

L.R.231

**GASCOIGNES · READING · ENGLAND**

Telephone: READING 54411 (6 lines)



# 'SPECIFICATION'

## Land Rover Conversion Unit

- 1) Starting Handle Dog
- 2) Rear Bearing Mounting Bracket
- 3) Prop. Shaft
- 4) Dog Clutch Assembly
- 5) Clutch Engaging Rod
- 6) Countershaft and Pulley to Power Unit
- 7) Front Bearing Mounting Bracket

### 'Shipping Details'

16in. x 10in. x 10in. 56 lbs.

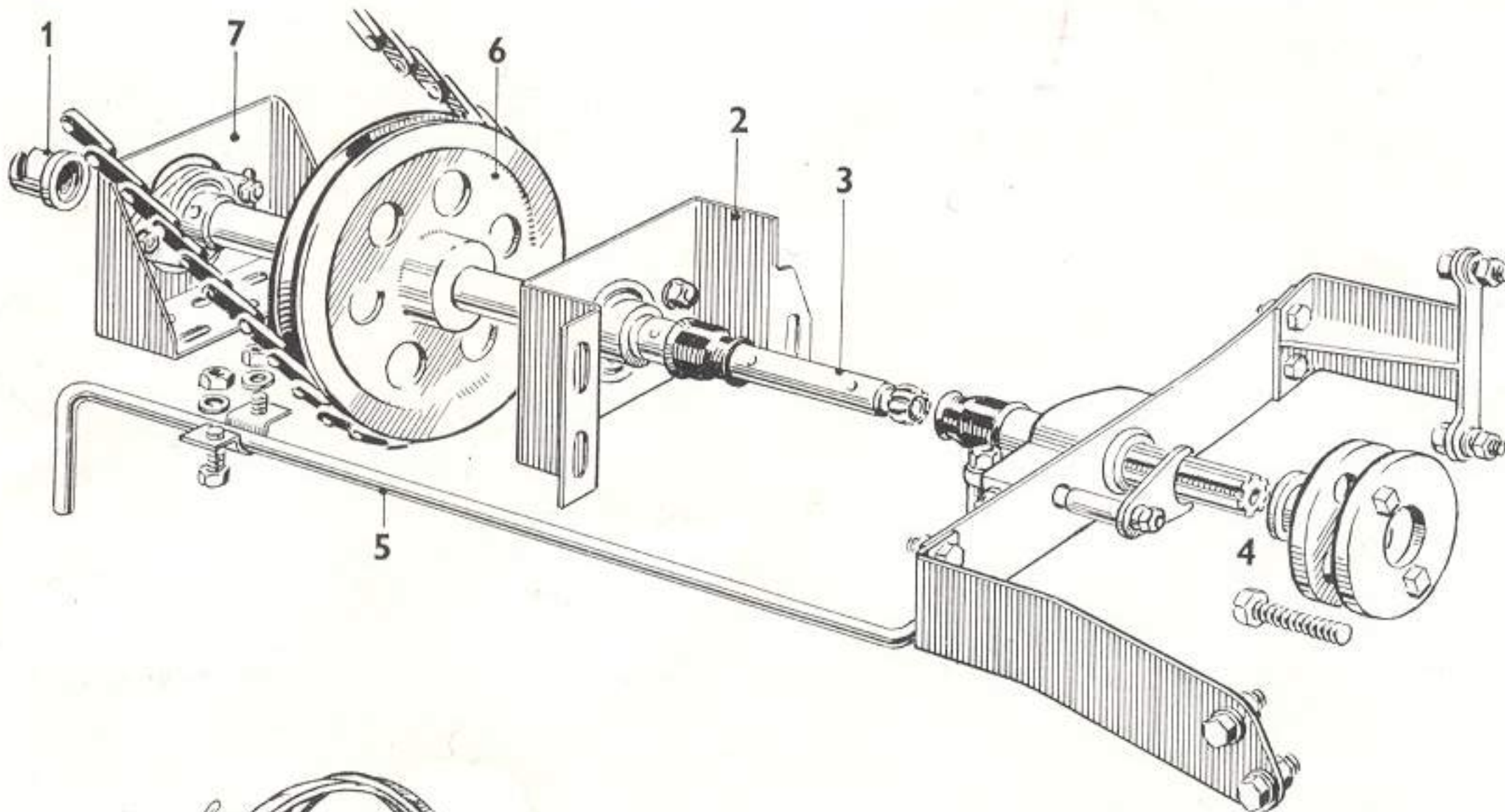

The unit is powered by direct drive from the front of the engine crankshaft and incorporates a dog clutch.

Correct vacuum pump speed of 1400 r.p.m. is achieved by opening the hand throttle on the vehicle to fast tick over 600 to 700 r.p.m. The Power Linkage system is supplied as a complete assembly with full instructions for fitting.

The Vacuum Pump unit is supplied complete, ready for mounting on the front bumper of the Land Rover.

Standard Gascoigne Bucket Units can be supplied but the equipment is suitable for any type of Bucket Milker.

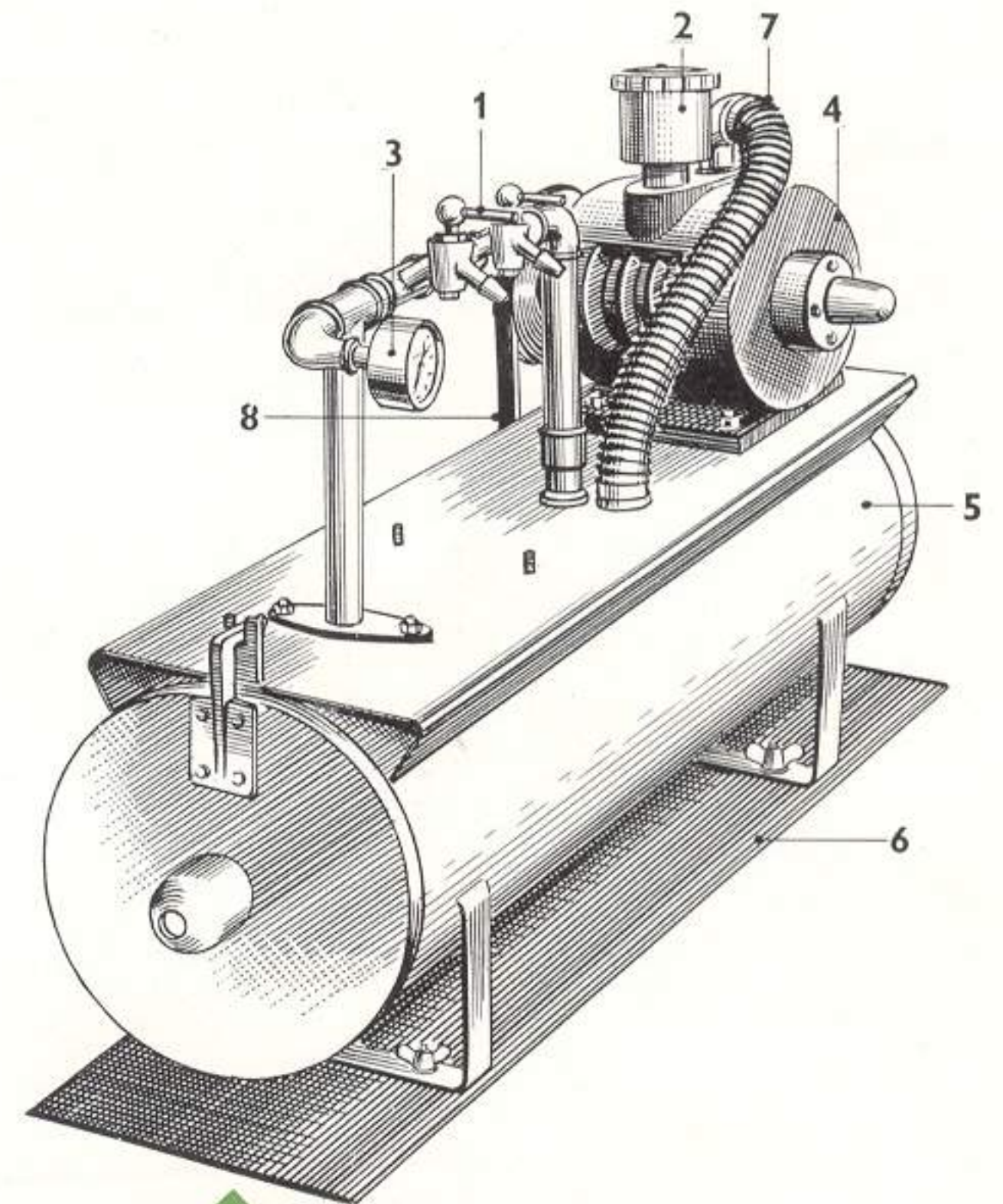

### Power Set

- 1) Vacuum Taps
- 2) Pump Lubricator
- 3) Vacuum Gauge
- 4) Vacuum Pump
- 5) Combined Sanitary Trap & Silencer
- 6) Base Plate
- 7) Induction Hose
- 8) Drive from Countershaft

### 'Shipping Details'

32in. x 9in. x 18in. 112 lbs.

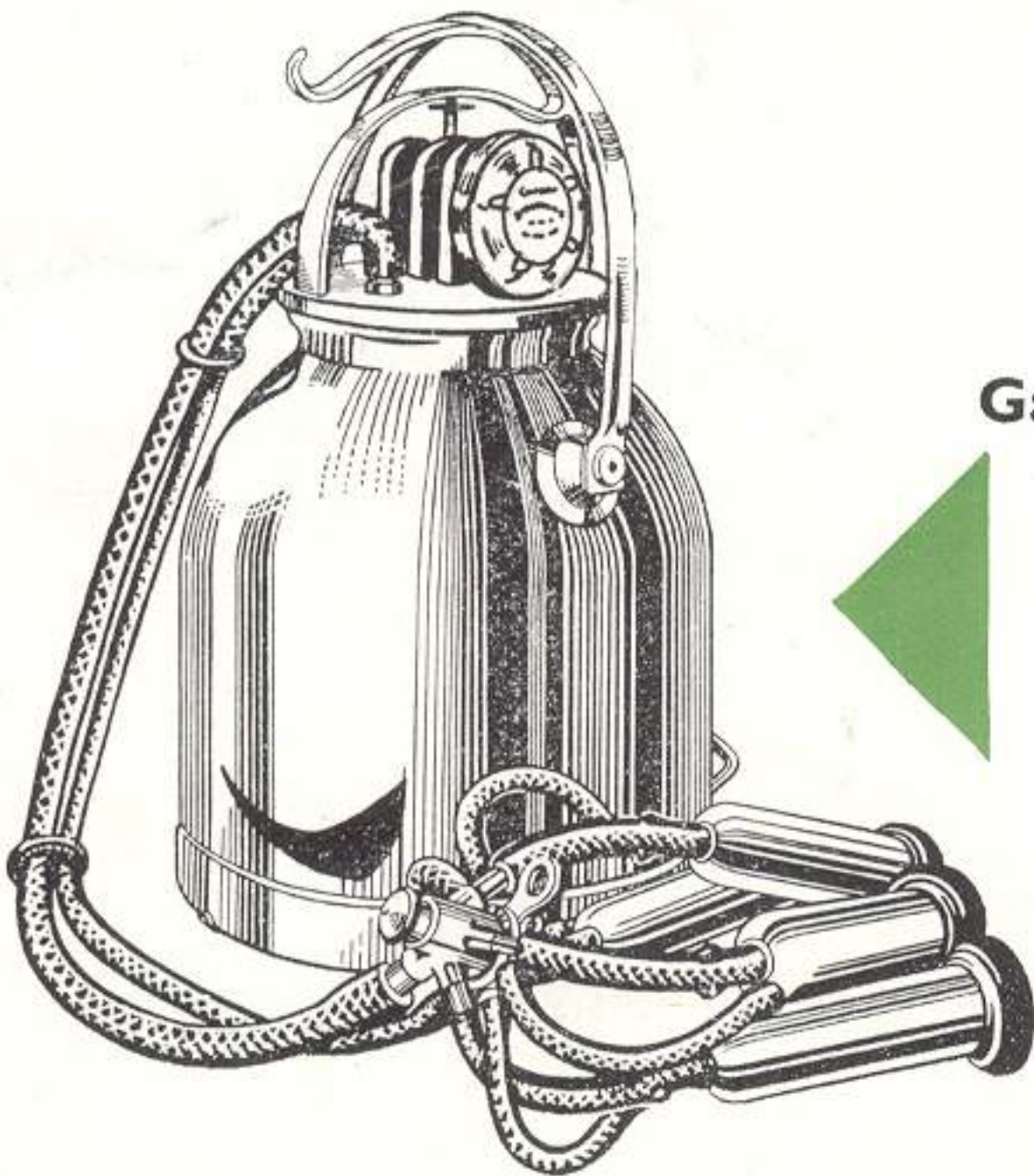

**Gascoigne Bucket Units** offer the ultimate in machine milking with all stainless steel components if desired. The Ratiomatic Pulsator gives wide ratio milking, the lead to higher yields.

"The Rover Company Limited is not responsible for the manufacture of approved equipment and/or bodywork, although they have closely examined specification and design. Matters concerning Sales (including Shipping, Delivery, etc.) Service or Warranty Claims are the responsibility of the manufacturer (whose name and address is given on this leaflet) or his agent. In cases of difficulty concerning approved equipment, the Special Projects Section of the Land-Rover Engineering Department is available to offer advice".

Land-Rover Extras required - NIL

Hand Throttle optional for Petrol Engined Models.