

D-B

ARTICULATED LAND-ROVER

AS APPROVED BY THE ROVER Co. Ltd.

LAND-ROVER



12-6 X 7-6 PLATFORM.



STANDARD 11-2 X 7-6 PLATFORM

35cwt LOW LOADING MODELS.

- A versatile, lightweight articulated vehicle, equally at home on or off the road.
- Wide range of semi-trailer designs for every purpose.
- Detachable pick-up body for quick and simple attachment to Land-Rover when Trailer is not in use.
- Automatic fifth wheel coupling and all fittings supplied as kit for easy fitting to chassis and cab unit.
- Existing vehicles can be converted.
- Does not affect the fitting of the majority of Rover approved equipment.

MANUFACTURED BY

B. DIXON-BATE LIMITED,
CHESTER

ENGLAND

TELEPHONE: CHESTER 24034 (5 Lines)

SPECIFICATION AND DETAILS

STANDARD LOW LOADING SEMI-TRAILER MODEL PD35FS

CHASSIS. Available in two standard widths, 6'-0" or 7'-6". Of robust all-welded construction with channel sidemembers and tubular crossmembers, all members being boxed and reinforced where necessary. Swan neck drawbar for maximum articulation over rough ground.

BODY. Low loading platform with 1 1/4" hardwood floor. Wheels recessed and fitted rubber wings. Two 6'-0" loading ramps supplied, forming sideboards when not in use.

SUSPENSION. Independent trailing arms on "Flexitor" torsional rubber springs with hydraulic dampers.

TYRES & WHEELS. 7.50-16 8 p.r. tyres on 5.50F x 16 Land-Rover wheels.

HUBS & BRAKES. Taper roller bearing hubs with 12" x 2 1/4" Girling brakes in "Chromidium" drums with vacuum operation by hydraulic reaction valve from vehicle hydraulic line. Handbrake lever fitted in front of headboard.

COUPLING. 2" S.A.E. kingpin for 18" fifth wheel.

LANDING GEAR. Screw action telescopic legs with wheels.

WINCH. 1 ton Thompson type, available as extra.

LIGHTING EQUIPMENT. Twin tail, stop and number plate lamps with reflectors and flashing indicators, connecting cable and waterproof plug. Side lamps fitted on wide chassis model.

STANDARD FINISH. Land-Rover green high gloss enamel, hardwood floor treated with wood preservative.

LAND-ROVER CONVERSION EQUIPMENT

STANDARD FITTINGS. 18" fifth wheel coupling on universal mounting, together with all vacuum brake and electrical fittings, number plate and rear rubber wings are supplied as kit with full instructions for quick and simple fitting, the major items all being on a sub-frame for clamping on to vehicle chassis.

DETACHABLE BODY. Of all-steel construction with hinged tailboard, for fitting to Land-Rover when trailer is detached. Quickly mounted without the use of tools, internal size 4'-0" long x 5'-0" wide x 1'-1" deep. Available as extra.

DIMENSIONS STANDARD MODEL	6 ft. wide		7'-6" wide	
	English	Metric	English	Metric
Overall Length	15'-9"	4.79 m.	15'-9"	4.79 m.
Overall Width	6'-1 1/2"	1.87 m.	7'-6"	2.29 m.
Platform Length	11'-2"	3.40 m.	11'-2"	3.40 m.
" Width fore and aft of wheels	6'-1 1/2"	1.87 m.	7'-6"	2.29 m.
" Width between wheels	4'-6 1/2"	1.38 m.	5'-10 1/2"	1.79 m.
" Height, unladen, approx.	21 3/4"	55 cm.	21 3/4"	55 cm.
" Height, laden, approx.	20"	51 cm.	20"	51 cm.
Min. Ground Clearance, laden, approx.	11 3/4"	29 cm.	11 3/4"	29 cm.
Track	5'-4 1/2"	1.64 m.	6'-8 1/2"	2.04 m.
Coupled Unit Overall Length	24'-5"	7.44 m.	24'-5"	7.44 m.
Payloads with 2 persons in cab.			English	Metric
Trailer max. load (load c.g. 5'-0" min. from headboard) Road use			35 cwt.	1778 Kg.
" " " " " 5'-9" min. from headboard) Cross-country			30 cwt.	1524 Kg.
Shipping Specification			English	Metric
Trailer unpacked 6'-0" model. 15'-9" x 6'-1 1/2" x 3'-3"			15 1/4 cwt.	775 Kg.
" " " " " 7'-6" " 15'-9" x 7'-6" x 3'-3"				
Vehicle fittings (packed on trailer platform)			2 cwt.	120 Kg.

The right is reserved to alter this specification

Details of other models on application

TYPICAL TRAILER VARIATIONS

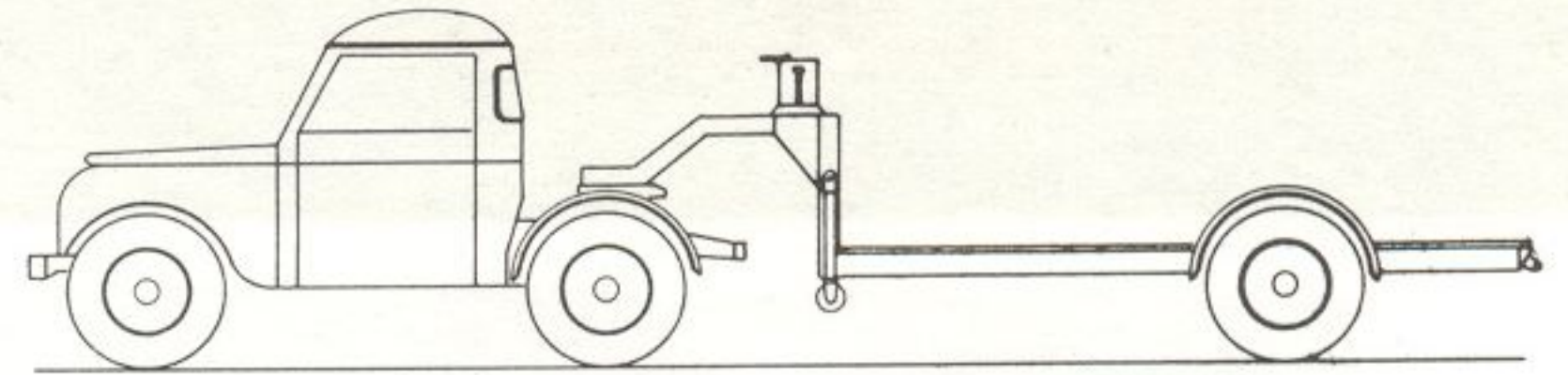

STANDARD LOW LOADING PLATFORM

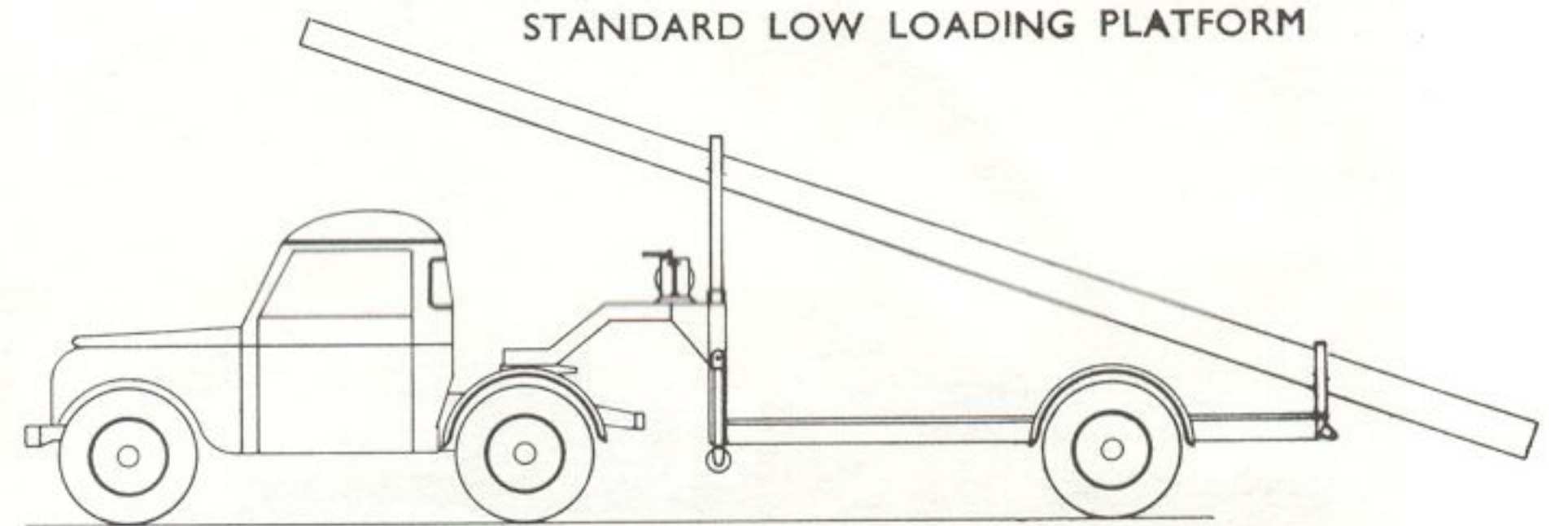

STANDARD LOW LOADING WITH POLE SUPPORTS

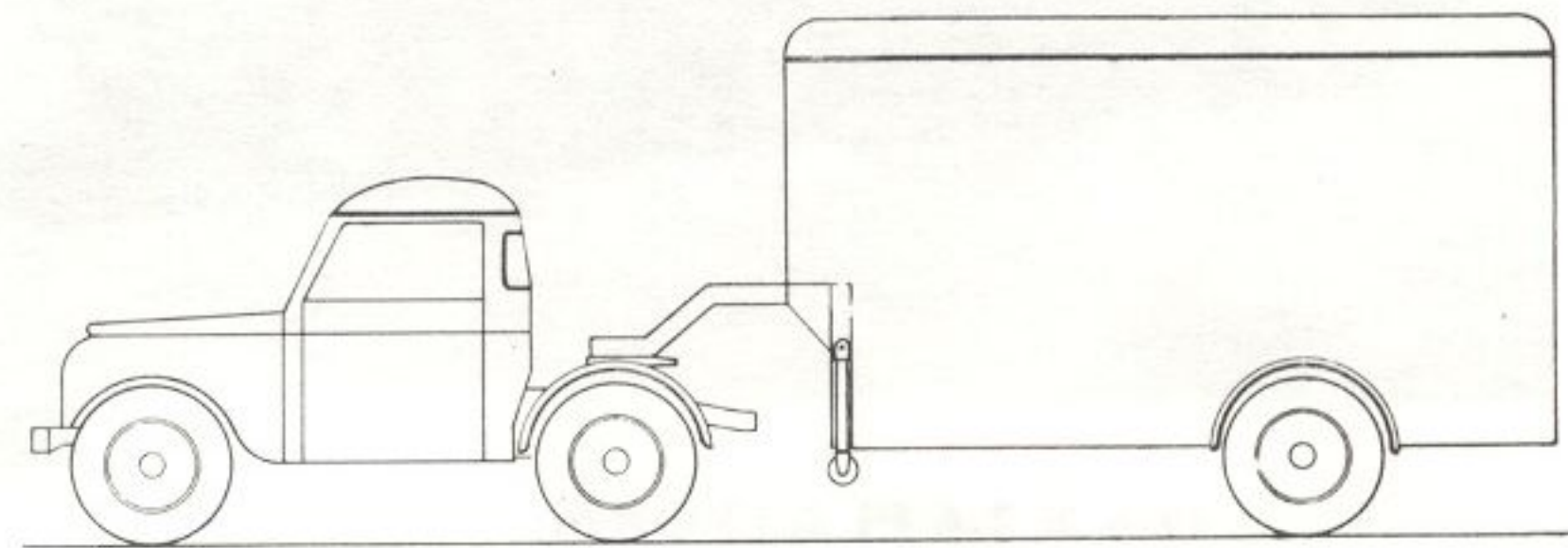

STANDARD LOW LOADING VAN

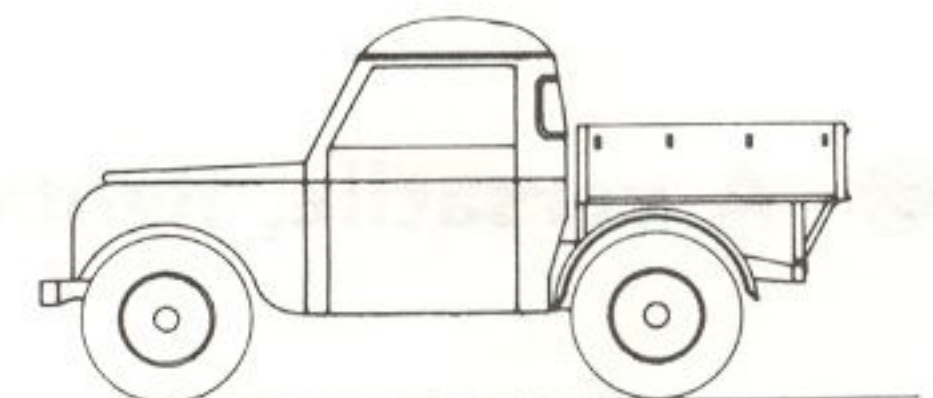

DETACHABLE PICK-UP BODY

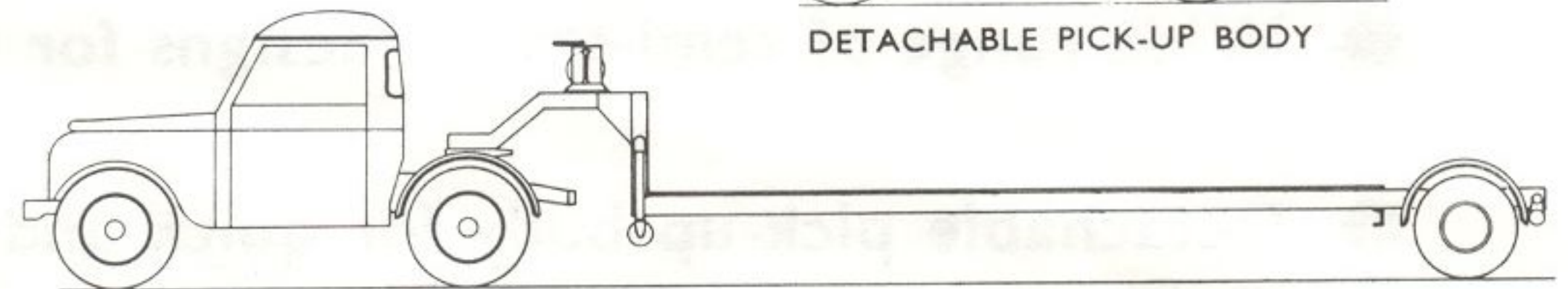

LOW LOADING WITH DETACHABLE AXLE FOR LIGHTWEIGHT BULKY LOADS

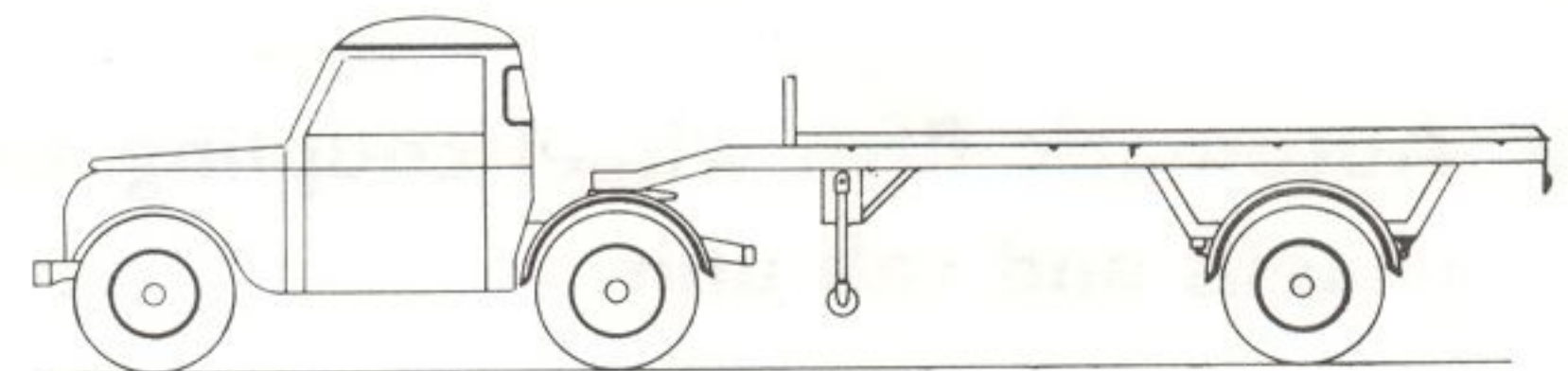

STRAIGHT FRAME PLATFORM

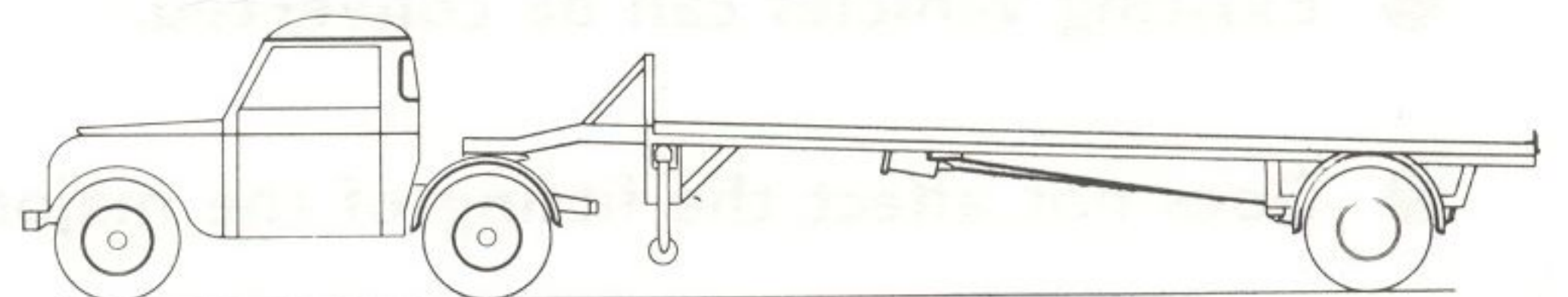

STRAIGHT FRAME FOR LIGHTWEIGHT BULKY LOADS

LAND-ROVER CHASSIS & CAB REQUIRED

TO SPECIFICATION TECH. SALES REF 2322/1

SPECIFICATION INCLUDES HEAVY DUTY SUSPENSION, 7.50-16 Tyres,

BONNET MOUNTED SPARE WHEEL, FLASHER EQUIPMENT, ETC.