

THE ROADLESS 109

Designed and developed with the assistance of The Rover Co. Ltd.
(Technical Sales Department)



Tested for over two years and thousands of miles, under a variety of severe conditions, including forestry, bogs, cross country and good and bad road surfaces. Large diameter wheels ensure low rolling resistance and high ground clearance on extreme surface conditions.

High drawbar pull . . . Wide wheel base gives excellent stability on side slopes . . . Heavy duty suspension built for cross country work . . . Will wade through water up to 2 ft. 6 ins. deep . . . Large diameter and wide tyre section gives low ground pressure necessary for bog and soft sand.

ROADLESS TRACTION LIMITED
HOUNSLOW · MIDDLESEX · ENGLAND

Telephone : Hounslow 6421

SPECIFICATION

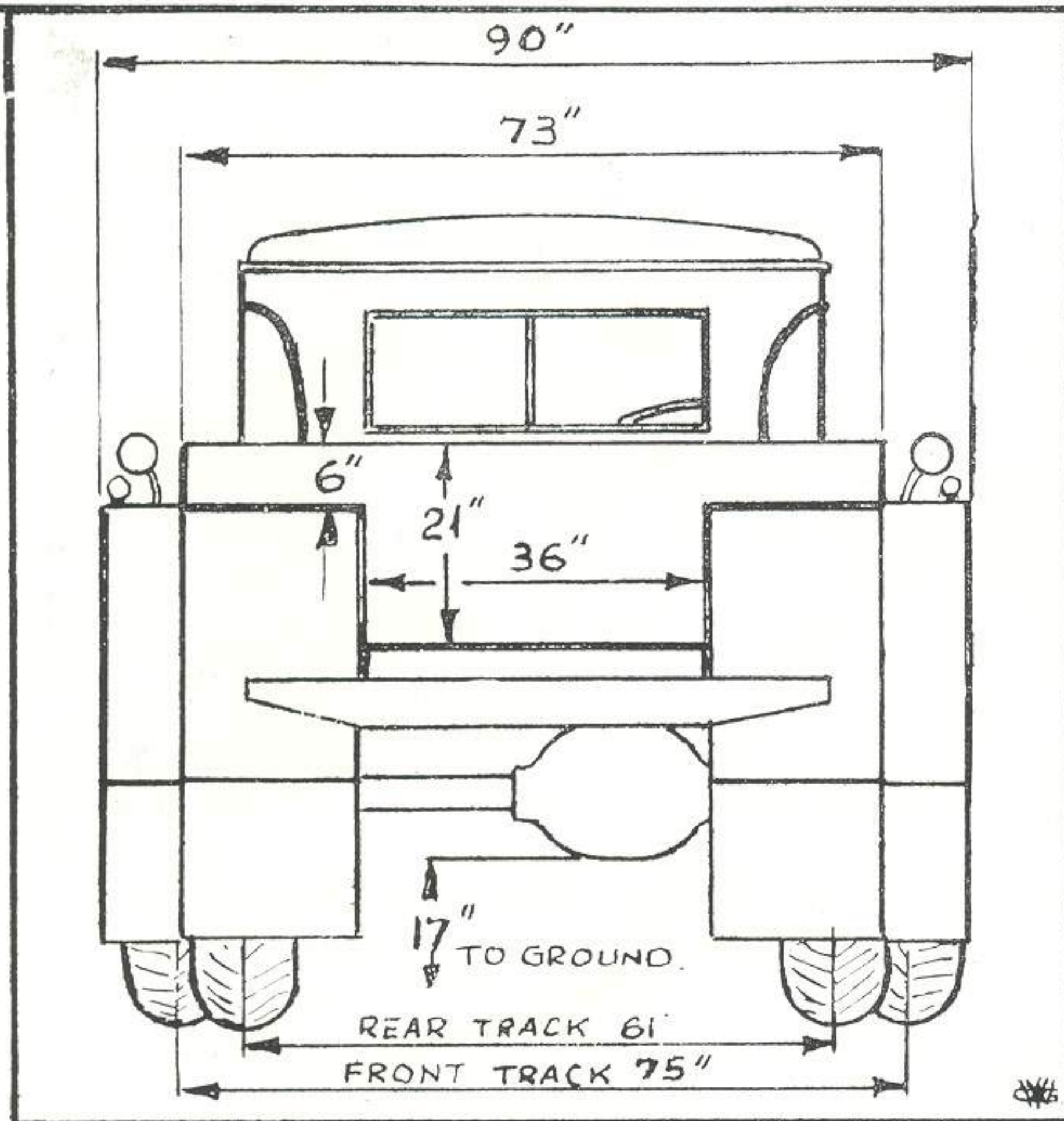
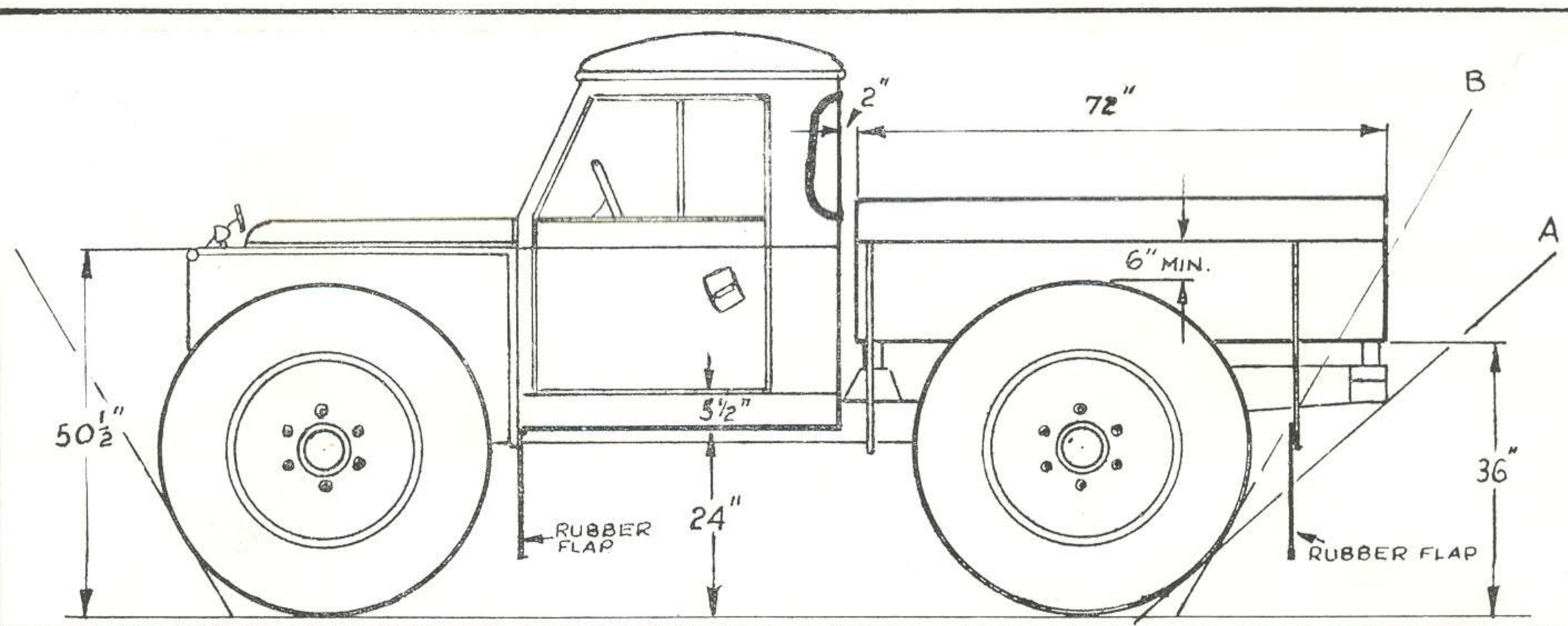

The power unit, clutch, main gear box, transfer box, propeller shafts, steering box, and certain body parts are standard 109" W.B. Land-Rover series II (petrol or diesel).

- ROAD SPRINGS** 109" W.B. Land-Rover, heavy duty, rubber bushes all round.
- SHOCK ABSORBERS** Heavy duty double acting.
- CHASSIS FRAME** 109" W.B. Land-Rover. Box section, reinforced where necessary.
- FRONT AXLE** Special Axle. Track 75". Differential ratio 3:63 : 1, hub reduction 3:67 : 1. Drive to front wheels through totally enclosed universal joints. Fully floating.
- REAR AXLE** Special Axle. Track 61". Differential 3:63 : 1, hub reduction 3:67 : 1.
- BRAKES** Hydraulic. 14" diameter Drums. Brake Lining width 2 1/2". Internal Expanding. Hand-brake mechanical on transfer box output shaft.
- WHEELS & TYRES** Standard 10.00 x 28 agricultural 4 or 6 ply. 11.00 x 28 and 13.00 x 28 also available.
- BODYWORK** Pick-up Body. Other types of body to purchaser's specifications.
- LADEN GROUND CLEARANCE** under Differentials 10.00 x 28 tyres—17". Under Lowest Part of Chassis Frame. 18"
- EXIT ANGLE** Line 'A' with Standard 109" W.B. Chassis. Approx. 40°.
Line 'B' with Shortened 109" W.B. (Optional Extra) Approx. 55°.
- PAYLOAD** Maximum on cross-country with driver and two passengers — 1500 lbs.
- VEHICLE WEIGHT** With Cab but less body 1 ton 17 cwt.
- SHIPPING DETAILS** Vehicle packed on wooden base, approximate overall length 178", width 94", height 50". 2 wheels bolted together 48" x 48" x 21" (each pair of 10 x 28).

LAND-ROVER EXTRAS REQUIRED

None is essential for the Conversion, but certain items available as optional equipment for the Standard 109" W.B. Land-Rover can be fitted.